

Performance Characteristics	
Operating Voltage	3.0 Vdc
Max. Current	200 mA
Free Flow	0.90 l/min
Flow at +30 mbar	0.70 l/min
Flow at +80 mbar	0.30 l/min
Flow at -30 mbar	0.45 l/min
Max Vacuum	- 100 mbars

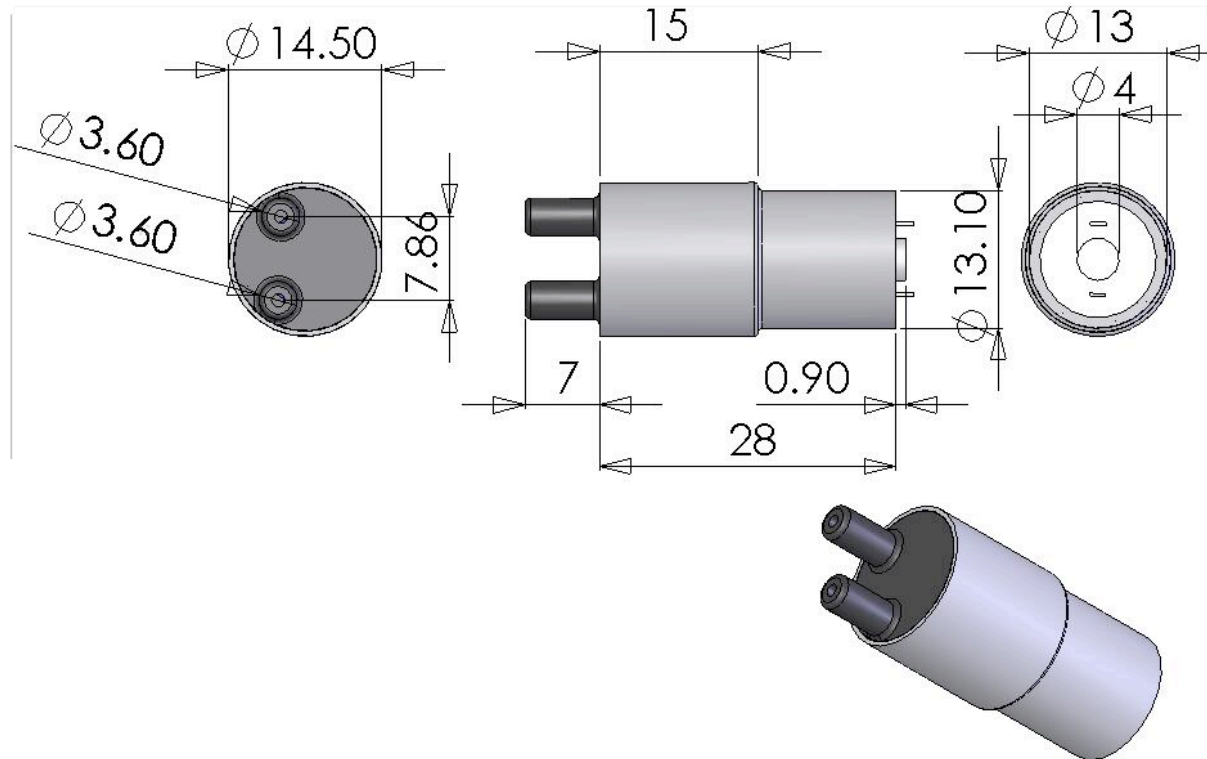

Every effort has been made to ensure the accuracy of this document at the time of printing. In accordance with the company's policy of continued product improvement MRB SCIENTIFIC Limited reserves the right to make product changes without notice. No liability is accepted for any consequential losses, injury or damage resulting from the use of this document or from any omissions or errors herein. The data is given for guidance only. It does not constitute a specification or an offer for sale. The products are always subject to a program of improvement and testing which may result in some changes in the characteristics quoted. As the products may be used by the client in circumstances beyond the knowledge and control of MRB SCIENTIFIC Limited, we cannot give any warranty as to the relevance of these particulars to an application. It is the clients' responsibility to carry out the necessary tests to determine the usefulness of the products and to ensure their safety of operation in a particular application. Performance characteristics on this data sheet outline the performance of newly supplied sensors. Output signal can drift below the lower limit over time.